



User's Manual

tPrime™ Series

280T-S Ultrasonic Heat Meter

UM280T-S170315V2

Created March 15, 2017

WARNING!

(1) The 280T-S heat meter is not certified for use in hazardous environments. The local site safety codes and regulations must be observed.

(2) The 280T-S heat meter contains Lithium batteries. Please check to see if they're working before using the heat meter. The batteries must be recycled or disposed of properly.

Contents

1. Introduction	1
§1.1 Preface.....	1
§1.2 Features	2
§1.3 Typical Applications	3
§1.4 Safety Instructions	3
§1.5 Automatic Meter Reading (AMR)	4
§1.6 Built-in Time-Keeper.....	4
§1.7Product Identification	5
2. Technical Information	6
§2.1Packing List.....	6
§2.2 Battery Specifications.....	8
§2.3Specifications	9
§2.4 Units systems.....	14

§2.5 How to protect the cables	14
§2.6 Serial number	14
§2.7 Model Selection.....	15
3. Operation	16
§3.1 Built-in Battery.....	16
§3.2 Power On.....	16
§3.3 Keypad	17
§3.4 Menu Windows.....	17
§3.5 How to check if the instrument works properly	21
§3.6 Battery life.....	22
4. Installation	23
§4.1 Location selection.....	23
§4.2 Flow-cell installation	24
§4.3 Temperature Sensor Installation	26
§4.4 Electronic Box Mounting Location.....	27
§4.5 Common installation mistakes.....	29

§4.6 Operations check	30
5. Troubleshooting	32
§5.1 Other Problems and Solutions	32
6. Interface/Communication	34
§6.1 General	34
§6.2 PC Software	34
§6.3 Communication Protocol	34
§6.4 Wiring Diagrams	38
§6.5 M-Bus Metering System	40
§6.6 BACnet Metering System	41
§6.7 Automatic Meter Reading	42
7. Warranty and Service	44
§7.1 Warranty	44
§7.2 Service	44
§8.1 Battery Maintenance and Replacement	46
§8.2 Principle of Measurement	46

§8.3 Heat Energy Calculation.....	46
§8.4 Water Density and Specific Enthalpy Tables.....	50
§8.5 Heat Meter Mounting Location	55

1. Introduction

§1.1 Preface

A member of the tPrime™ Series, the 280T-S ultrasonic heat meter offers the most advanced BTU measurement in the market by using state-of-the-art ultrasonic flow measurement technology. The 280T-S does not have moving parts to wear out, thus it literally requires no maintenance. It is also very cost-effective, especially in the long run. This means both commercial and residential installations can profit from the advantages of wear-free heat measurement, such as precision, operating security, and long service life.

With its maximum operating temperature of 95 °C and nominal pressure of 1.6MPa, the technical specifications meet the standard for residential meters. The high measurement dynamic allows a load of up to double the rating, thereby ensuring high operating security.

The 280T-S heat meter uses transit-time ultrasonic flow measurement principle to reliably measure the flow rate: sending and receiving transducers in opposition send ultrasonic signals alternately with and against the flow direction. The flow rate can be precisely calculated from the difference between the two transit times. There are no moving components in the sensor, and as a result, the measurement is wear-free and stable over a very long time period.

Suitable for both commercial and residential applications, this compact meter fits in even the smallest installation conditions and can be mounted separately from the electronics console. The meter includes an order option for remote read-out (pulse, M-Bus, or RS485 output). The large display can be set to display heat consumption, temperatures, flow total, working time, velocity, etc.

The 280T-S also offers tools for building energy management. When equipped with an M-Bus module, the heat meters can be networked through a two-wire bus to a central location for integrated resource management. An optional concentrator and data acquisition software make the whole system installation and integration easy. Spire Metering provides a complete AMR (automatic meter reading) solution as well.

Spire Metering's 280T-S Ultrasonic BTU meter stands out among its competitors due to its unique reflector-free sensor design. The 280T-S is able to work reliably even when the water is dirty, which is useful because the HVAC circuit could be like this after years of operation. Both commercial and residential installations can profit from the many advantages of wear-free heating/cooling energy measurement, such as precision, operation security and long service life.

§1.2 Features

- Wear-free ultrasonic measurement. No maintenance needed
- Proprietary robust sensor design. No reflector, thus works reliably for both clear water and dirty water
- Excellent long-term stability. Accuracy does not degrade over time
- Not impacted by water impurity or magnetic interference
- Wide measurement range
- Low pressure drop
- For both hot and cold water
- Free positioning for mounting
- Battery supply for 5 years
- Nominal pressure up to 1.6MPa
- M-Bus / RS485 for remote readout
- Optional BACnet or M-Bus concentrator
- Optional AMR and data management software, including meter reading software and utility billing software
- Simple and easy to install. Electronic box can be detached from the sensor body and installed separately
- Low cost over long run, low cost of ownership

§1.3 Typical Applications

The 280T-S is suitable for both commercial and residential applications, such as district heating and cooling, HVAC, green energy management, and AMR and billing. It meets the standards of industrial, utility, and submetering systems:

- Wider dynamic range allows for a load of up to double the rating, thereby ensuring high operational security
- Maximum operating temperature of 95 °C
- Nominal pressure of 1.6MPa

This compact meter fits into even the smallest installation locations and can be mounted separately from the electronics console.

The large LCD screen can be set to display the heat consumption, temperature, flow total, working time, flow velocity, etc. The meter also has a remote readout which can be configured as M-Bus or RS485. An optional BACnet module is available upon request.

§1.4 Safety Instructions

- Never hold and transport the meter by the electronics box, but instead only by the flanged or threaded joint
- Assembling and dismantling should be carried out only when there is no pressure in the pipe
- Beware of sharp edges
- After installation, the tightness must be verified by pressurizing with cold water
- Use meter only under the specified operating conditions

When conducting pressure test, make sure the pressure does not exceed 2.5MPa. Otherwise, dangers may arise and will void the warranty

Make sure the flow rate range does not exceed the specifications

- Calibration, maintenance, replacement of components, and repairs must only be performed by a qualified person familiar with the hazards involved
- Calibration-related seals of the heat meter must not be damaged or removed! Otherwise, the warranty will be void
- Disposal of the Lithium battery must be in accordance to environmental regulations
- We regret that we do not provide lightning protection, however, lightning protection should still be ensured through other proper means

§1.5 Automatic Meter Reading (AMR)

AMR is a system for building energy management. When equipped with a connection module, multiple 280T-S heat meters can be networked through a two-wire bus to a central location for integrated resource management. Spire Metering Technology provides an entire system of AMR solutions, making the system installation and integration very easy.

Its SpireCapture™ system is a cutting-edge fixed AMR system which integrates both wired and wireless AMR/AMI technologies. It can accommodate a variety of metering networks, such as M-Bus, and BACnet. The data center software communicates with those networks through a standardized platform, which allows you to start with a simple AMR system and gradually expand to a large metering system.

For more information on AMR and serial communication, see Section §6.

§1.6 Built-in Time-Keeper

A time-keeper is integrated in the 280T-S heat meter. The time-keeper remains operating as long as the battery is alive. In case of battery failure, the time-keeper will not keep running, and the time data will be lost. The user must re-enter the proper time values after the battery failure is recovered.

The user can also set the date and time as desired.



§1.7 Product Identification

Each set of the 280T-S series heat meter has a unique product identification number or ESN written into the software that can only be modified with a special tool by the manufacturer. In case of any hardware failure, please provide this number.



2. Technical Information

§2.1 Packing List



DN 15-40

Item	Description	Quantity	Unit	Notes
1	Ultrasonic Heat Meter (Integrator with a pair of temperature sensors and one flow sensor)	1	set	
2	T-connector (also called thermal well) with temperature sensor port	1	piece	
3	Tail piece (also called extension piece) with nut and gasket	1	set	
4	Installation Guide	1	copy	

DN 50 and DN65

Item	Description	Quantity	Unit	Notes
1	Ultrasonic Heat Meter (Integrator with a pair of temperature sensors)	1	set	
2	Flowcell Sensor	1	piece	
	Mounting pocket	1		
3	Installation Guide	1	copy	

DN 80 and above

Item	Description	Quantity	Unit	Notes
1	Ultrasonic Heat Meter (Integrator with a pair of temperature sensors)	1	set	
2	Flowcell Sensor	1	piece	
	Thermal-well & Mounting pocket	1	Set	
3	Installation Guide	1	copy	

§2.2 Battery Specifications

Lithium-Thionyl Chloride ER18505Type Battery

Dimensions: 18.5mm diameter by 50.5mm height

Weight: average: 28g

Nominal Capacity: 4 Ah

Nominal Voltage: 3.6V

Max Recommended Continuous Current: 130mA

Max Pulse Current Capability: 180mA

Operating Temperature Range: -60°C to 85°C

Storage Temperature: Up to 30°C

§2.3 Specifications

DN15-DN40:

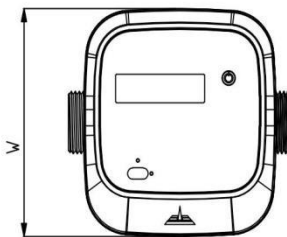
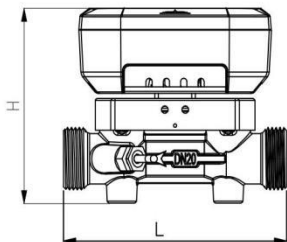

DN50 and above:

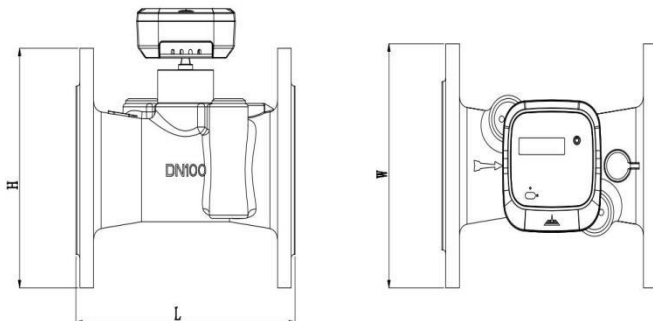

Dimension Table:

DN Size mm	Flowrate (m ³ /h)			Dimension (mm)			Weight* (kg)	Pipe Joint	
	Q _{min}	Q _n	Q _{max}	L	W	H		(BSP/DIN)	
							Sensor	Ext.	
DN15	0.03	1.5	3	110	120	100	1.2	G3/4B	G1/2B
DN20	0.05	2.5	5	130	120	105	1.2	G1B	G3/4B

DN25	0.07	3.5	7	160	120	110	1.6	G1 1/4B	G1B
DN32	0.12	6	12	180	120	120	2.2	G1 1/2B	G1 1/4B
DN40	0.2	10	20	200	120	125	2.8	G2B	G1 1/2B
DN50	0.6	15	30	200	165	197	10.8	4-M16	
DN65	1	25	50	200	185	211	14.5	4-M16	
DN80	1.6	40	80	225	200	227	16.9	8-M16	
DN100	2.4	60	120	250	220	247	19.9	8-M16	
DN125	4	100	200	250	250	242	26.2	8-M16	
DN150	6	150	300	300	285	277	29.0	8-M20	
DN200	10	250	500	350	340	327	48.9	12-M20	
DN250	16	400	800	450	405	412	93.9	12-M22	
DN300	24	600	1200	500	460	467	113.9	12-M22	

**Notes: Weight may differ depending on accessories.*

Electrical Data

Power Supply:	Battery, 3.6V, Lithium
Battery type:	Lithium, 3.6V
Battery life:	5 years
Backup Power Supply:	Internal SuperCap
Communication Interface:	M-Bus (default) Optional: RS485 with MODBUS support, BACnet/MSTP
CE approval:	EN61326-1:2006
Pressure:	≤1.6 MPa
Press loss:	≤17KPa
Replacement Interval:	5 years at $t_{BAT} < 30\text{ °C}$ (86 °F)
Power Supply:	Automatically switch to battery power if Mbus or RS485 power is not available
Power Consumption:	<0.2W
Standby (Static) Current:	<10uA

Accuracy / MPE (Maximum Permissible Error)

Accuracy Class: Class 2

MPE according to OIML R75, the whole system error is the combination of the following:

- Calculator (Integrator): $E_c = \pm(0.5 + 2 / \Delta\Theta)$
- Temperature Sensor: $E_t = \pm(0.5 + 4 / \Delta\Theta)$
- Flow Sensor: $E_f = \pm(2 + 0.02 q_n / q)$

Here $\Delta\Theta$ is the temperature difference between the flow and return of the heat exchange circuit. q is the flow rate and q_p is the nominal flow rate.

Calculator (Integrator)

Display:	LCD, 8 digits
Resolution:	999.99999 - 999999.99 - 99999999
Energy Unit:	KWh – MWh – GJ
Communication Protocol:	M-Bus (default). Optional: MBus EN13757, MODBUS or BACnet

Temperature Measurement

Sensor Type:	Pt1000, 2-wire
Measurement Range:	0-95 °C (32-203 °F)
Difference Range:	Δ (2.5K-85K)
Permissible Temperature:	2 °C-60 °C(35-140 °F) for long term and up to 95 °C(203 °F) for short term

Mechanical Data

Metrological Class:	2
Environmental Class:	B
Electromagnetic Class:	E1
Environmental Temp:	0-55 °C (32-131 °F)
Enclosure Protection:	IP68

Integrator Detachable:	Yes
Pressure:	PN16
Flow Sensor Cable:	1.2m
Temperature Sensor Cable:	1.5m

§2.4 Units systems

Currently, the 280T-S device does not support additional unit systems, and so it measures everything in Celsius and kWh by default. However, one can use these simple equations to convert between units:

If you prefer to use BTU as the unit for energy, you may use the formula $1 \text{ kWh} = 3412.3 \text{ BTU}$.

If you prefer to use °F as the unit for temperature, you may use the formula $°F = °C * (9/5) + 32$.

§2.5 How to protect the cables

When mounting the sensors, please be careful not to touch the meter wires. All cables must be properly protected so that no damage, short-circuit, or disconnection occurs to the device.

§2.6 Serial number

First, go to the main menu layer. Then, cycle through the menus until you reach energy kWh. The serial number is in the screen right after energy kWh.

§2.7 Model Selection

280T - SDN - - - -

Size	ID	Size	ID
DN15	015	DN80	080
DN20	020	DN100	100
DN25	025	DN125	125
DN32	032	DN150	150
DN40	040	DN200	200
DN50	050	DN250	250
DN65	065	DN300	300

Output Interface	ID
M-Bus (Default)	1
RS485/Modbus	2
BACnet/MSTP	3
Other, please specify	4

Pipe Joint	ID
BSP	A
NPT (Meter body will have BSP threading with NPT Extension pieces)	B
DIN Flange	C
Other, please specify	D

Temperature	ID
Standard Temperature	A

Pressure	ID
1.6MPa (232 psig)	1

3. Operation

§3.1 Built-in Battery

The instrument operates from the built-in Lithium battery, which is long-lasting with 5 years of operating time. The terminal voltage reaches around 3.6V. If the 280T-S is connected to an outside power source, such as M-Bus, the meter will not use the battery but instead draw power directly from the M-Bus.

Due to transport regulations, the battery might be deactivated by an insulating strip, which must be removed completely in order to activate the meter. If a replacement battery is needed, please contact Spire Metering. If the meter needs to be sent by air freight, then the battery must be removed prior to shipping.

For safety precautions, the batteries should not be opened, come into contact with water, or be exposed to temperatures above 80 °C. Batteries should be disposed of at proper collection centers.

§3.2 Power On

First, make sure to activate the battery. The meter starts with full screen display and then stays on the window HEAT (GJ).

Then press the button on the front panel, it cycles through different display windows such as supply water temperature (F temp), return water temperature (R temp), temperature difference (Δt), working time (hr), serial number, date, flowrate, and etc.

The heat measurement program always operates in the background of the user interface. This means that the heat measurement will keep running regardless of any user window browsing or viewing.

§3.3 Keypad

The keypad of the 280T-S heat meter has 1 key for all functions.

§3.4 Menu Windows

The user interface of this heat meter comprises of several results displays that can be viewed.

In order to get into a certain menu window, the user can press the button to change the LCD display. The heat meter calculates the results and updates the display every 8 seconds. The following values can be displayed:

- Total Energy (kW h or MW h)
- Power (kW)
- Serial Number
- Full Screen Display
- Cool (GJ)
- Cool(kWh)
- Flow(m³)
- Flowrate (m³/h)
- F temperature (°C)
- R temperature (°C)
- Delta (change) in temperature (Δt)
- Total Working Time(h)
- Current Date
- DN Size

Each short press of the button switches the display screen to the next item. The menus are displayed in loop-fashion. After pressing the button, the display may stay at an item for a short time and then return to the original display item.

These are the top layer (main menu) of the menu display structure. On the second layer **【F】** layer of this structure, more information can be seen. To enter the calibration menu **【F】**, press UM280T-S170315V2

the button for 3 seconds to enter it. To go from the main menu to the **【F】** layer, press the button in any menu for 3 seconds, and you should see “F” on the LCD all the time. Click the button again, you will see menu “Flow” and there is “TEST” blink every now and then. This indicates that you are ready to view the menus on the **【F】** layer.

On the **【F】** layer, the following menus are displayed:

- Total Volume with High Resolution (5 decimals)
- Total Energy with High Resolution (3 decimals)
- Flowrate

- Supply water temperature (F-Temp)

- Return water temperature (R-Temp)
- Delta T

- To go back to the main menu layer, leave it over one hour, it will automatically switch to main menu layer.

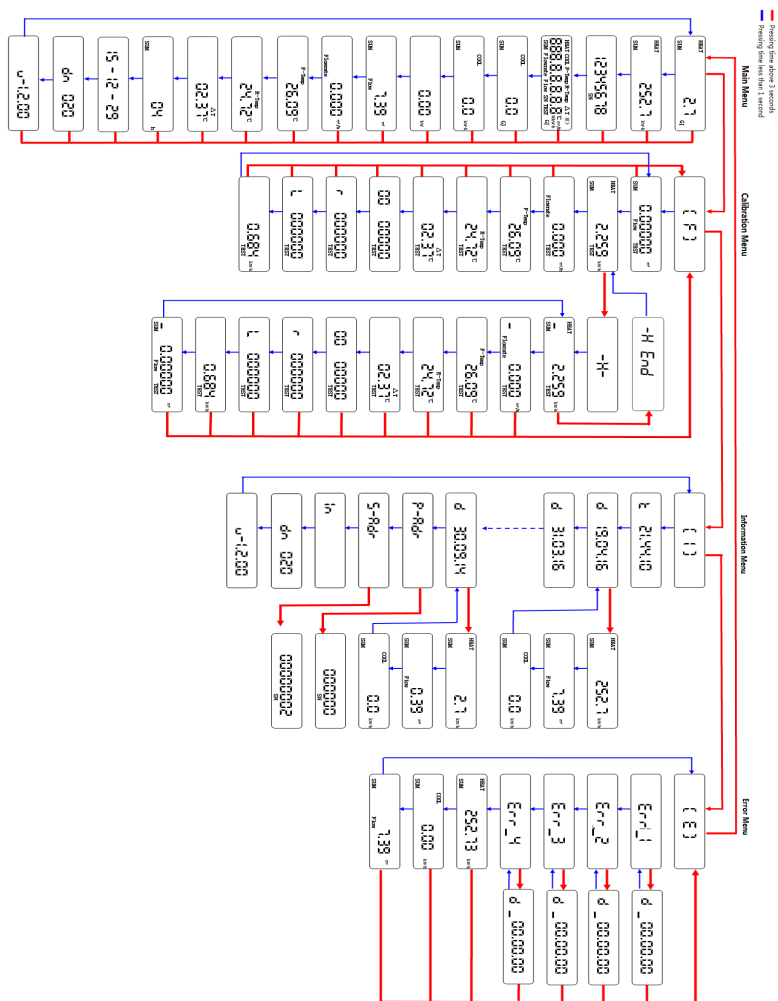

§3.5 How to check if the instrument works properly

◇ Check the heating/cooling system is working or not

◇ Check the stop valve opening or not

◇ Check if there are foreign substances in the pipe

◇ Check the sealing of BTU meter is intact

◇ Check the battery usage

◇ If the BTU meter doesn't work,

a. the BTU meter has been installed backward.

b. the transducers' wires are disconnected.

c. the upstream pipe or strainer is blocked

◇ How to check if the strainer is blocked

The supply water temperature is normal, but the return temperature is too low. The temp difference is above 10°C, and velocity is too low or no velocity. Either the strainer is blocked or the user doesn't use the heating/cooling.

Solution:

Close the valve of pipe(supply, return valve), and take the strainer off. If the strainer is black, then clean it. Install the strainer and then open the pipe valves. Wait for 3 minutes see if the velocity and temperature are normal.

◇ What to do when the energy readings abnormal or jumping:

a. The installation location is not proper. The PT1000 sensor should be installed at return

pipeline.

b. The length of straight pipe before /after meter's flow cell sensor is too short, and the bend is too long or the pipe reducing is too big. Make sure the straight pipe before the flow cell sensor is 10D and after the flow cell sensor is 5D.

◇The meter has flow but no energy or the energy reading is too big.

a. No energy is because of temperature sensors installed reversely.

b. Big energy reading means the temperature sensors inaccurate and the temperature difference is big.

◇The temperature of BTU meter is abnormal or temperature is 0.

a. The temperature is broken.

b. The broken or twisted stainless steel sleeves of temperature sensors causes short circuit.

§3.6 Battery life

See the battery icon on the top right corner. Four bars signify almost full battery in the device.

4. Installation

§4.1 Location selection

- Find a suitable location for connecting the flow cell (the “tube” part of the device where water flows through) to the pipe line.
- Do not install the meter within 0.5m of an AC power line or a high-frequency radiation source.
- It is recommended to have a 5D straight pipe run upstream and 2D straight pipe run downstream, where D stands for pipe diameter.
- When two or more heat meters are installed closely, make sure they are distanced by 0.3m or more.
- If the flow meter is installed on the common return of two heating circuits (e.g. heating water and hot water), the mounting location must be at a sufficient distance, at least 10D, from the Tee, to ensure that different temperatures homogenize (refer to the figure on the bottom).
- For more information on optimal location, go to Appendix §8.4.

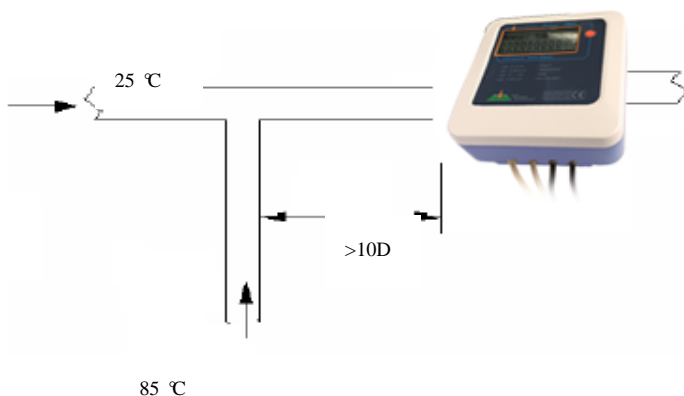

§4.2 Flow-cell installation

- When installing, make sure the arrow on the meter sensor points to the flow direction.
- When installing, do not turn the electronic box. When using a wrench to install, hold the metal part of the sensor rather than the electronics box.
- When the meter is used as cold meter, remove the meter's main box and its mounting base and install the main box on a wall or other objects where the temperature is within 0~55°C. In addition, the meter box needs to be higher than the cold pipe, so that the condensed water on the cold pipe will not flow into the meter box along the wires.
- The meter sensor can be installed vertically or horizontally:
When it is installed vertically, make sure the flow goes upward.
When it is installed horizontally, make sure the ultrasonic transducers of the flow-cell are on the side instead of the top or the bottom (please refer to the figure below)

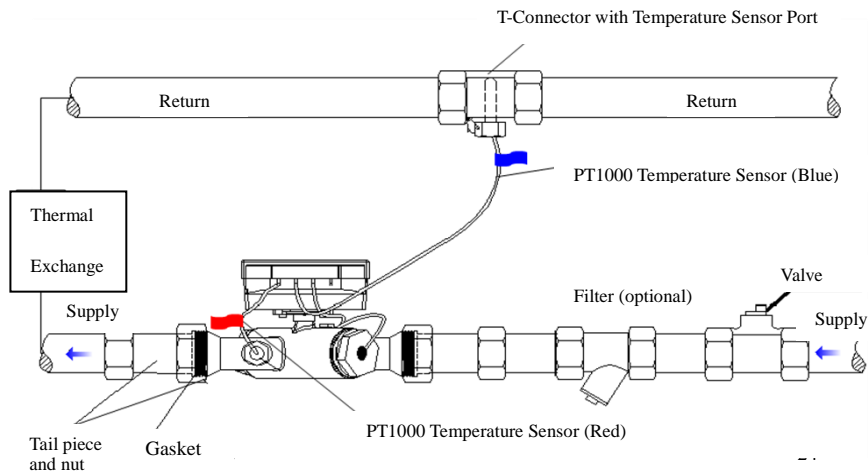

-
-
- Flange connection
 - (1) Check the flow-cell dimension and reserve sufficient clearance for the flow-cell installation.
 - (2) Install flexible flanges if applicable (DN50-100), see next section for details
 - (3) Install the flow-cell between two shut-off valves.

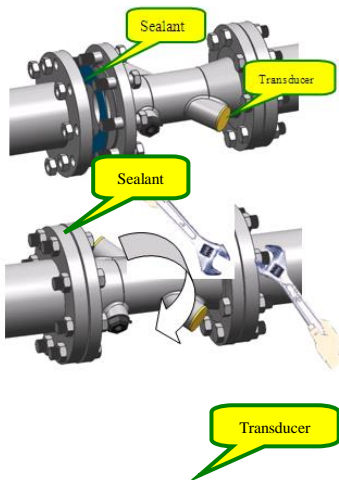

§4.3 Temperature Sensor Installation

For DN 15-40

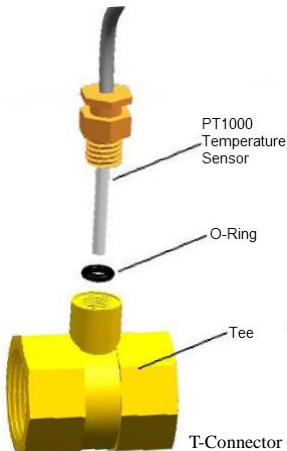

The red-labeled Temperature Sensor should be already pre-plugged into the flow cell. In order to install the blue-labeled Temperature Sensor on the return pipe, follow these steps:

- (1) Insert the Tee into the desired location along the pipe line.
- (2) Remove the Temperature Sensor Port plug from the Tee.
- (3) Insert the O-Ring deep inside the Temperature Sensor Port.
- (4) Gently insert the blue-labeled Temperature Sensor into the Tee's Temperature Sensor Port, being careful not to break the O-Ring, and then tighten it.

For DN50 and above

- (1) Install the red-labeled temperature sensor into the temperature sensor mounting pocket on the flow-cell. Refer to the lower left figure for details.
- (2) On the return pipe (assuming the heat meter is installed on the supply pipe), make a hole with size slightly bigger than the mounting pocket.
- (3) Insert the mounting pocket into the hole and weld it onto the return pipe.
- (4) Install the blue-labeled temperature sensor into the mounting pocket:
 - For DN80 and larger meters, refer to the lower center figure.
 - For DN50 and DN65 meters, refer to the lower right figure.



Mounting Pocket (Supply)

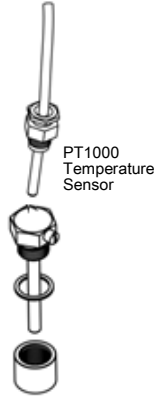

Thermal-well sleeve

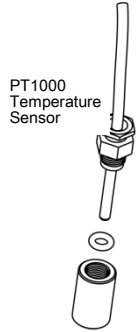

O-ring

Please wrap

Thermal-well

Sleeve

PT1000
Temperature
Sensor

Mounting

Mounting

Temperature sensor

For sizes ≥ DN80

For sizes DN50 and DN65

§4.4 Electronic Box Mounting Location

The electronic box can be mounted horizontally, vertically, or inclined on the meter mounting base of the flow sensor.

- (1) Make sure the surrounding temperature is less than 55 °C. If not, remove the meter mounting base and install it together with the electronic box on a wall that is at room

temperature.

- (2) If the water temperature is higher than 90 °C, remove the meter mounting base and install it together with the electronic box on a wall.
- (3) When used as a cold meter, remove the meter mounting base and install it together with the electronic box on a wall. In addition, the box should be above the pipe so that no condensed water will drop onto the box or run along the wire into the box.

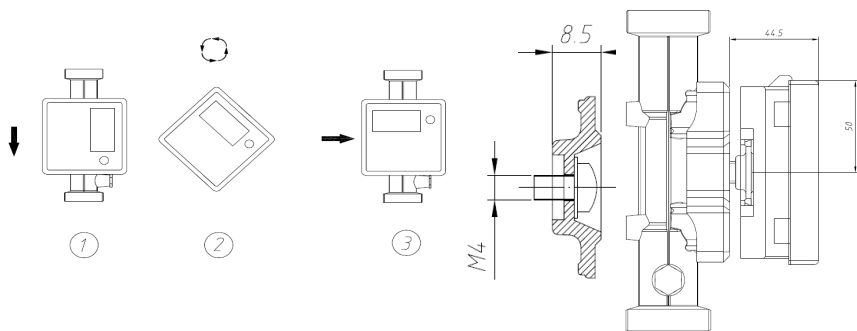

§4.5 Common installation mistakes

Use both wrenches when tightening the nuts

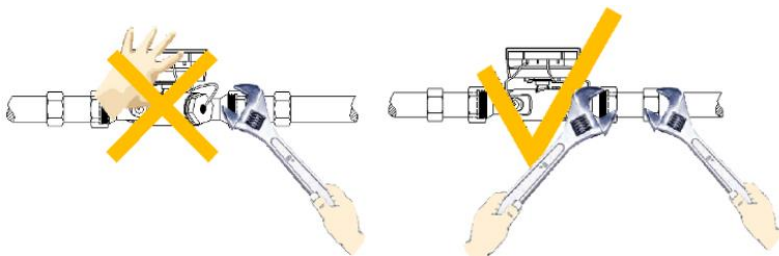

For horizontal pipes, the flow-cell should be installed in a way so that the meter box faces upward and the two ultrasonic transducers on the horizontal plane.

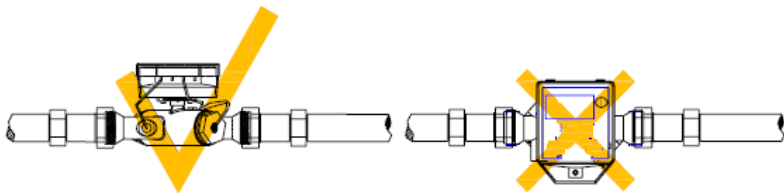

The pipe must be full of liquids.

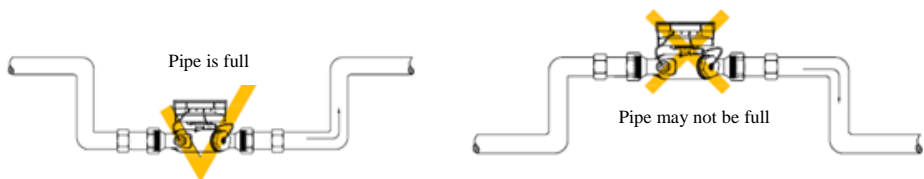

For vertical installation, the flow must go upward.

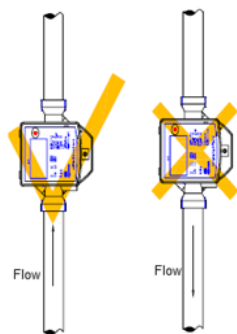

Flow

Flow

§4.6 Operations check

- After the installation is complete, the air in the pipe has to be purged out completely.
- Make sure the pressure in the system is normal.
- Make sure the red temperature sensor is installed in the temperature sensor port of the flow-cell, and the blue temperature sensor is installed in the temperature

sensor port of the Tee. For pipe sizes DN65 or bigger, you may need to drill a hole to install the blue temperature sensor. Please contact the manufacturer for instructions.

- Make sure the O-ring for the sealing is centered at the joining point. Otherwise, it could generate disturbance to the flow, thus, degrading the meter accuracy.
- Use meter only under the specified operating conditions. Make sure flow rate range is proper for the pipe.
- If the heating system is not running in winter, always empty the pipe. Otherwise, the pipe may burst when water freezes.
- Important: The pipe must be full of liquids during operation!

5. Troubleshooting

§5.1 Other Problems and Solutions

- (1) Q: Why does the instrument display 0.0000 flow rate while the liquid in the pipe is actually flowing?

A: There might not be enough water in the pipe. Try to get it so that water flow through the flow cell is almost full. Additionally, check the installation to see if it is in a desirable location.

- (2) Q: The displayed flow rate is much lower or much higher than the actual flow rate in the pipe under normal working conditions. Why?

A:

- (a) The flow cell and meter might have been installed incorrectly. Check the connection.
 - (b) The amount of straight pipe run upstream and downstream may be too small. This can cause the data reading to be inaccurate.
 - (c) When the meter sensor is installed vertically, make sure the water flow goes upward. When it is installed horizontally, make sure the ultrasonic transducers of the flow cell are on the side instead of the top or bottom, as this may skew results.
- (3) Q: Why is the temperature reading incorrect?

A:

- (a) When 2 or more heat meters are installed closely, make sure they are separated by 0.3m or more, otherwise the measurements are affected.
- (b) Make sure the temperature sensor is installed correctly in the temperature sensor port.
- (c) Make sure the meter box is not in direct contact with the pipe if it's used as a cold meter.

6. Interface/Communication

§6.1 General

The tPrime™ 280T-S series ultrasonic heat meter integrates a USB communication interface and a complete set of serial communication protocol. By using this serial communication link, one can configure the heat meter and acquire measurement results from a PC. Additionally, the 280T-S heat meter has multiple AMR/AMI integral options, including:

- M-Bus
- RS485 / Modbus
- BACnet

§6.2 PC Software

To facilitate the use of and to fully explore the potential of 280T-S heat meter, Spire Metering has developed proprietary PC software, which is particularly useful for meter trouble shooting, meter reading, AMR and etc.

§6.3 Communication Protocol

These are the main methods to read data from tPrime™ 280T-S heat meters: Infrared Meter Reading, RS485 Meter Reading, M-Bus Meter Reading, and BACnet Meter Reading. Infrared reading is a local meter reading method. The others are remote meter reading methods. The communication protocol discussed here is applicable to remote reading methods.

Master-Slave communication architecture. The 280T-S meter is the slave.

Use RS485 serial communication. Default parameters are:

UM280T-S170315V2

- Baud Rate: 9600 bps
- Checksum: None
- Data bit: 8 bits
- Stop bit: 1 bit

With the MODBUS module option, the 280T-S supports standard MODBUS protocol, function code 03 and 06 for register reading and writing.

280x MODBUS PROTOCOL

280x series water meters and heat meters support MODBUS function code 03 and 06 for reading a register and writing to a single register. Default port setting is 9600,n,8,1

Register Address	# of registers	Variable Name	Data Type	Notes
0001-0002	2	Flow Rate	LONG	*
0003-0003	1	Flow Rate Unit	INTEGER	*
0004-0005	2	Power	LONG	*
0006-0006	1	Power Unit	INTEGER	*
0007-0008	2	Flow Total	LONG	*
0009-0009	1	Flow Total Unit	INTEGER	*
0010-0011	2	Heat Energy Total	LONG	*
0012-0012	1	Heat Energy Total Unit	INTEGER	*
0013-0014	2	Cold Energy Total	LONG	*
0015-0015	1	Cold Energy Total Unit	INTEGER	*

0016-0017	2	T1 /Supply Temp	LONG	x0.01degC
0018-0019	2	T2 /Return Temp	LONG	x0.01degC
0020-0020	1	State	INTEGER	
0021-0022	2	Working Time	LONG	Unsigned. second
0023-0024	2	Clock	BCD	Writable. 3bytes BCD for second, minute and hour. Low on left
0025-0026	2	Date	BCD	Writable. 4bytes BCD for day, month and year. Low on left
0027-0027	1	4-20mA output current value	INTEGER	x0.01 mA
0028-0029	2	Flowrate/Energy rate at 4mA	LONG	Unit similar to (0003)
0030-0031	2	Flowrate/Energy rate at 20mA	LONG	Unit similar to (0006)
0032-0032	1	Size	LONG	mm (saved in flash)
0033-0034	2	SN#	BCD	High on left
0035-0035	1	MODBUS ADDR	INTEGER	Writable (saved in flash)
0036-0036	1	Meter Type	INTEGER	BIT0=0:water meter BIT0=1:heat meter (saved in flash)
0037-0037	1	Comm Mode Select	INTEGER	Writable. 0 - 9600/MODBUS (Default); 1- 2400/Mbus**
0038-0038	1	Firmware Version	INTEGER	Hex

Notes:

*Unit code:

05 – KWH; 14 – Watt; 08 – GWH;

17– KW; 1A – GW; 29 – Litre;

0B – KJ; 0E – MJ; 11 – GJ;

32 – Litre/H; 33 – 0.01 *Cubic Meter/H. 34 – 0.1 *Cubic Meter/H.

35 – Cubic Meter/H.

2A – 0.01 *Cubic Meter; 2B – 0.1 *Cubic Meter; 2C – Cubic Meter;

Data Format:

For LONG data, it has 32bits. Thus, two registers are used to store a LONG.

The first register (lower address) is for the lower 16bits of the data. The second register (higher address) is for the higher 16bits of the data.

** Use factory software to change communication protocol. If you set the Comm Mode to 1, and set the duration to 6556, then the meter will switch to M-Bus protocol. Reset the external power will switch the mode back to MODBUS protocol.

M-Bus Protocol:

Master-Slave communication architecture. The 280T-S meter is the slave.

Use M-Bus serial communication. Default parameters are:

- Baud Rate: 2400 bps
- Checksum: Even
- Data bit: 8 bits
- Stop bit: 1 bit

The 280T-S adapts the EN13757 M-Bus protocol. This allows it to communicate with any standard M-Bus master device.

Please note that only the major functions of the protocol have been implemented.

§6.4 Wiring Diagrams

M-Bus Interface:

tPrime™ 280T-S (DN 10-40)		
Number	Wire Name	Color
1	Return Temperature Sensor	Blue Flag
2	Supply Temperature Sensor	Red Flag
3	Transducer Cable	Black
4	M-Bus Output Wires	Red (Plus)
		Blue (Minus)



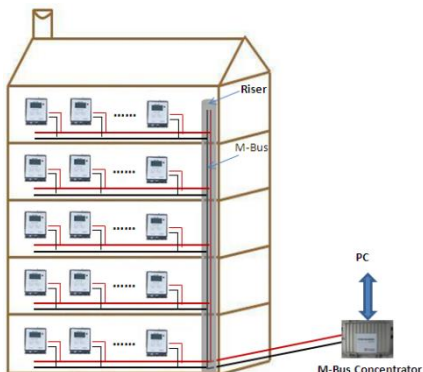

Two wires, no polarity.

Wire size: AWG22 or bigger, depending on distance.

Wire length: <1km

Twisted cable with shielding is better.

Once 280C-1 concentrator can support up to 120 M-Bus meters.

Refer to the figure on the left for details.

RS485 Interface:

tPrime™ 280T-S (DN 10-40)		
Number	Wire Name	Color
1	Return Temperature Sensor	Blue Flag
2	Supply Temperature Sensor	Red Flag
3	Transducer Cable	Black
4	RS485/MODBUS Output Wires	Red (VCC)
		Black (GND)
		Blue (A)
		Yellow (B)



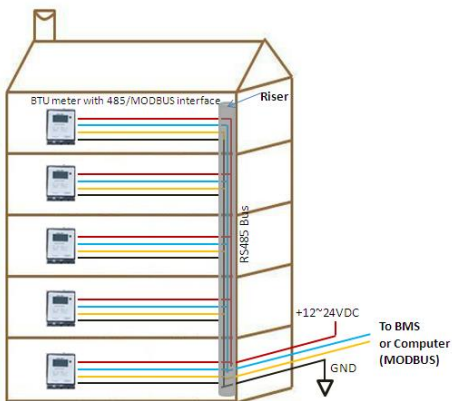

The RS485 output is an opto-isolated serial interface. It needs an external 12~24VDC/1A power supply.

This communication port setting is fixed at 9600,8,n,1.

This serial interface supports standard MODBUS protocol.

§6.5M-Bus Metering System

M-Bus Cable

The M-Bus uses two wire cables which are going from the M-Bus Master / Repeater to each M-Bus device (bus structure). The M-Bus is polarity independent and needs no line termination resistors at the end of the cables.

Any cable type may be used as long as the cable is suitable for 42 V / 500 mA. Shielding is not necessary and not recommended since the capacity of the cable should be minimized.

In most cases a standard telephone cable is used which is a twisted-pair wire with a diameter of 0.8 mm each (2 x 0.8 mm). This type of cable should be used for the main wiring. For the wiring to the meters from the main wiring (last 1 ... 5 m to the meter) a cable with smaller diameter may be used.

Please refer to the picture in section §6.4 for wiring details.

The M-Bus system is an European instrument “bus” standard designed for domestic metering devices, such as water meters, heat/water meters, gas meters, etc., to communicate with data centers. The “bus” simply uses two non-polarized wires to achieve a variety of options for reliable meter reading, remote diagnosis, remote control, incremental pricing, time-based pricing, batch service, prepaid billing, and more. This ‘bus’ system is both simple and economical to wire and implement.

§6.6BACnet Metering System

The 280T-S meter can utilize a BACnet/MSTP adapter to provide the BACnet interface. It connects to the BACnet/MSTP adapter through RS485 and uses the MODBUS protocol to communicate. The BACnet adapter has passed the BTL certification test. It has proven to be robust, reliable, and flexible. The BACnet module has two banks of DIP switches, enabling the users to quickly configure the serial protocol settings without the need for any third party software. Settings available via the DIP Switches include

- MAC address
- Baud rate (including auto-baud setting for BACnetMSTP)
- Node ID

The BACnet module supports the following protocols:

- BACnetMSTP
- MetaSysN2
- Modbus RTU
- Modbus ASCII
- Allen Bradley DF1

The data link layer options include BACnet IP (Annex J), MSTP master (Clause 9), with a baud rate of up to 76.8 Kbps, and MSTP slave (Clause 9). The networking options are BACnet/IP Broadcast Management Device (BBMD), as well as registrations by foreign devices.

The standard object types supported by BACnet interface are device object, analog input,

analog output, analog value, binary input, binary output, binary value, multi state input, multi state output, multi state value, and notification class object.

§6.7 Automatic Meter Reading

Spire Metering's SpireCapture™ system is a cutting-edge fixed AMR system which integrates both wired and wireless AMR/AMI technologies. It provides a unified platform for meter reading and data management through M-Bus networks, RF wireless networks, as well as TCP/IP networks. In addition, the AMR system works seamlessly with Spire Metering's billing software to make data exchange easy, fast and reliable.

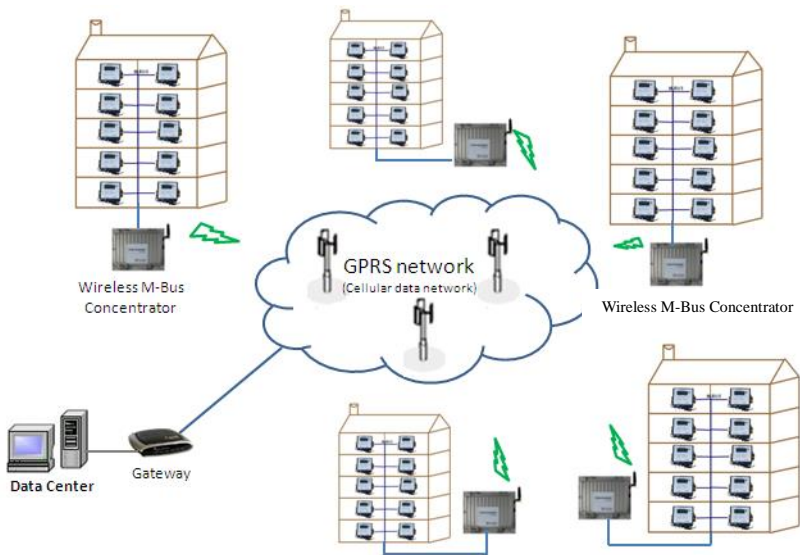

SpireCapture™ is an advanced, highly robust meter reading solution that delivers comprehensive usage information as well as timely, high-resolution meter reading. This data

enables gas, water, heat and electric utilities to eliminate on-site visits and estimated reads, reduce theft and loss, implement time-of-use billing, and profit from all of the financial and operational benefits of a fixed-network AMI/AMR.

SpireCapture™ is based on a flexible, expandable, multi-tier architecture that can accommodate a variety of metering networks. The data center software communicates with those networks through a standardized platform, which allows you to start with a simple AMR system and gradually expand to a large metering system. SpireCapture™ communicates with utility meters using primarily the MBus protocol. It can also be extended to other protocols such as Modbus. This allows other brand utility meters to be integrated into the SpireCapture™ system.

7. Warranty and Service

§7.1 Warranty

The products manufactured by Spire Metering Technology are warranted to be free from defects in materials and workmanship for a period of one year from the date of shipment to the original purchaser. Spire Metering's obligation is limited to restoring the meter to normal operating conditions or replacing the meter, at Spire Metering's choice, and shall be conditioned upon receiving written notice of any alleged defect within 10 days after its discovery. Spire Metering will determine if the return of the meter is necessary. If it is, the user will be responsible for the one-way shipping fee from the customer to the manufacturer.

Spire Metering is not liable for any defects or damage attributable to misuse, improper installation, out-of-spec operating conditions, replacement of unauthorized parts, and acts of nature. Additionally, fuses and batteries are not part of this warranty.

THE FOREGOING WARRANTY IS EXCLUSIVE AND IN LIEU OF ALL OTHER EXPRESS OR IMPLIED WARRANTIES (INCLUDING BUT NOT LIMITED TO WARRANTIES OF MERCHANTABILITY AND FITNESS FOR A PARTICULAR PURPOSE, AND WARRANTIES ARISING FROM DEALING, TRADE OR USAGE.)

§7.2 Service

The manufacturer provides instrument installation services for its customers, and the charge will depend on the complexity of the installation.

For operational problems, please contact the technical support department by telephone, fax, or email. In most cases, the problem can be resolved immediately.

For any hardware failure of the instrument, we recommend our customers to send back the instrument for service. Please contact the technical support department with the model number and serial number of the unit before sending the unit back to us. Both numbers can be found on the product label. For each service or calibration request, we will issue a Return Materials Authorization (RMA) number.

Take notice that the cost for repairing can only be determined after receipt and inspection of the instrument. A quotation will be sent to the customer before proceeding with the service.

Important Notice for Product Return

Before returning the instrument for warranty repair or service, please read the following carefully:

1. If the return item has been exposed to nuclear or other radioactive environments, or has been in contact with hazardous material which could pose any danger to our personnel, the unit cannot be serviced.
2. If the return item has been exposed to or in contact with dangerous materials, but has been certified as hazard-free device by a recognized organization, you are required to supply the certification for the service.
3. If the return item does not have a RMA number associated, it will be sent back without any service conducted.

8. Appendix

§8.1 Battery Maintenance and Replacement

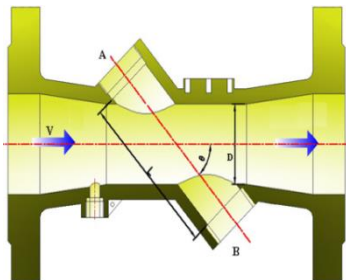

The battery is a Lithium non-rechargeable battery. Therefore, one needs to replace the batteries once they run out of power (usually lasts 5 years). Please contact the manufacturer for purchasing new batteries. Dead batteries should be disposed of at proper collection centers.

§8.2 Principle of Measurement

The tPrime™ series 280T-S heat meter consists of an ultrasonic flow sensor, a pair of PT1000 temperature sensors, and a BTU unit. The microprocessor-based BTU unit controls the ultrasonic sensor to transmit and receive ultrasound in an orderly fashion in order to conduct precise flow measurement. The BTU unit also has electronics dedicated to measure the temperature in the supply pipe as well as the return pipe via PT1000 sensors. The BTU unit calculates the heat energy based on the flowrate and the temperature difference between the supply and the return.

The figure on the right illustrates how the ultrasonic flow sensor works. Two ultrasonic transducers (A and B) are mounted on a spool piece face-to-face; one is on the upstream and the other on the downstream. The electronic console (e.g., the BTU unit) operates by alternately transmitting and receiving a burst of sound energy between the two transducers and measuring the transit time it takes for sound to travel between the two transducers. The difference in the transit time measured corresponds directly to the velocity of the liquid in the pipe.

§8.3 Heat Energy Calculation

In today's heat meter industry, there are two kinds of methods to calculate heat energy based on volume flow and temperature measurements. One method is to use the heat coefficient table, using this equation.

$$Q = \int_{v_0}^{v_1} k \Delta\Theta dV$$

where:

Q is the quantity of heat given up or absorbed

V is the volume of liquid passed

k is called the heat coefficient, a function of the properties of the energy-conveying liquid at the relevant temperatures and pressure

$\Delta\Theta$ is the temperature difference between the flow and return of the heat exchange circuit

The true conventional value of the heat coefficient (k) for water, if it is used as the system's heat conveying liquid, can be obtained from a standard heat coefficient table.

Another method is to use the specific enthalpy table. Spire Metering Technology's BTU meter utilizes the second method to calculate the heat energy of a heat exchange circuit. The advantage of this method is that the flow sensor can be installed in either the supply or return line, as long as the Red-tagged temperature sensor is installed on the flow sensor side. The equation is below:

$$Q = \int_{\tau_0}^{\tau_1} \rho q_v \Delta h d\tau$$

where:

Q is the total heat given out or absorbed, from time τ_0 to τ_1 , [J] or [Wh]

$\rho(T_s, T_r)$ is the density of the liquid passed [kg/m³]

$\Delta h(T_s, T_r)$ is the specific enthalpy difference, calculated from the supply and the return line temperatures, in [J/kg].

To calculate heat (Q) accurately, both flow and temperature measurements must be accurate. Of the two, measuring flow rate is more challenging, as all of the values in the integral on the right side of the equation below must be correctly measured, determined, or pre-calibrated.

Here are the equations used to find q_v

$$T_{up} = L / (C - V \cos \theta) \quad T_{down} = L / (C + V \cos \theta)$$

$$V = \frac{L}{2 \cos \theta} \times \frac{\Delta T}{T_{up} \bullet T_{down}}$$

and $q_v = k S V$

where:

Θ is the angle between the flow direction and the sound path

L is the transducer separation

T_{up} (T_{down}) is the transit time upstream (downstream), and $\Delta T = T_{up} - T_{down}$

k is a factory-calibrated scale factor, a function of the sensor structure and the fluid properties

S is the cross-sectional area of the flow at the sensor

The figure on the right illustrates a heat measurement system using the 280T-S meter. The temperature sensors measure the supply and the return lines, while flow rate is calculated as given above. The 280T-S calculates the heat transferred, Q, during a time interval, using the equations.

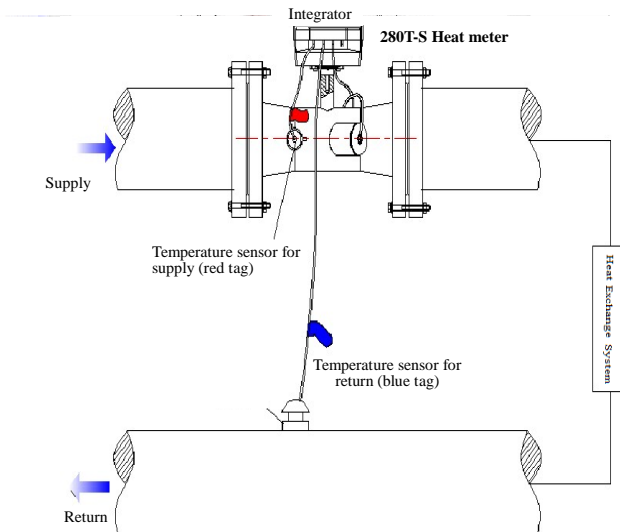

Depending on the pipe size, there are two kinds of transducer arrangements. For large pipes, a straight-through design is recommended. However, for small pipes, the straight-through does not provide enough sound path to obtain good accuracy. To increase the sound path, our competitors put a sound reflector in the pipe to get a V-shaped path or even put two sound reflectors to get a U-shaped path. The problem with the reflector occurs when the liquid in the pipe gets dirty, which is quite common in real heating/cooling loops. After many years in operation, the reflector surface is not smooth anymore, and its reflecting efficiency becomes very poor. This could cause the heat meter accuracy to be largely degraded, or even cause the meter to fail to register. With expertise on flow dynamics, Spire Metering Technology has designed a unique flow guide which allows the sound path to be more than 5 times longer than the straight-through design. This design significantly increases the measurement accuracy. Since there is no reflector, the sensor is very robust and reliable.

§8.4 Water Density and Specific Enthalpy Tables

A1. When pressure is less or equal 1.0MPa:

Table 1 $P = 0.6\text{MPa}$, Temperature $1^{\circ}\text{C} \sim 150^{\circ}\text{C}$

Temp ($^{\circ}\text{C}$)	Density (kg/m^3)	Enthalpy (kJ/kg)	Temp ($^{\circ}\text{C}$)	Density (kg/m^3)	Enthalpy (kJ/kg)	Temp ($^{\circ}\text{C}$)	Density (kg/m^3)	Enthalpy (kJ/kg)
1	1000.2	4.7841	51	987.80	214.03	101	957.86	423.76
2	1000.2	8.9963	52	987.33	218.21	102	957.14	427.97
3	1000.2	13.206	53	986.87	222.39	103	956.41	432.19
4	1000.2	17.412	54	986.39	226.57	104	955.67	436.41

tPrime™ 280T-S Ultrasonic Heat Meter

5	1000.2	21.616	55	985.91	230.75	105	954.93	440.63
6	1000.2	25.818	56	985.42	234.94	106	954.19	444.85
7	1000.1	30.018	57	984.93	239.12	107	953.44	449.07
8	1000.1	34.215	58	984.43	243.30	108	952.69	453.30
9	1000.0	38.411	59	983.93	247.48	109	951.93	457.52
10	999.94	42.605	60	983.41	251.67	110	951.17	461.75
11	999.84	46.798	61	982.90	255.85	111	950.40	465.98
12	999.74	50.989	62	982.37	260.04	112	949.63	470.20
13	999.61	55.178	63	981.84	264.22	113	948.86	474.44
14	999.48	59.367	64	981.31	268.41	114	948.08	478.67
15	999.34	63.554	65	980.77	272.59	115	947.29	482.90
16	999.18	67.740	66	980.22	276.78	116	946.51	487.14
17	999.01	71.926	67	979.67	280.97	117	945.71	491.37
18	998.83	76.110	68	979.12	285.15	118	944.92	495.61
19	998.64	80.294	69	978.55	289.34	119	944.11	499.85
20	998.44	84.476	70	977.98	293.53	120	943.31	504.09
21	998.22	88.659	71	977.41	297.72	121	942.50	508.34
22	998.00	92.840	72	976.83	301.91	122	941.68	512.58
23	997.77	97.021	73	976.25	306.10	123	940.86	516.83
24	997.52	101.20	74	975.66	310.29	124	940.04	521.08
25	997.27	105.38	75	975.06	314.48	125	939.21	525.33
26	997.01	109.56	76	974.46	318.68	126	938.38	529.58
27	996.74	113.74	77	973.86	322.87	127	937.54	533.83

tPrime™ 280T-S Ultrasonic Heat Meter

28	996.46	117.92	78	973.25	327.06	128	936.70	538.09
29	996.17	122.10	79	972.63	331.26	129	935.86	542.35
30	995.87	126.28	80	972.01	335.45	130	935.01	546.61
31	995.56	130.46	81	971.39	339.65	131	934.15	550.87
32	995.25	134.63	82	970.76	343.85	132	933.29	555.13
33	994.93	138.81	83	970.12	348.04	133	932.43	559.40
34	994.59	142.99	84	969.48	352.24	134	931.56	563.67
35	994.25	147.17	85	968.84	356.44	135	930.69	567.93
36	993.91	151.35	86	968.19	360.64	136	929.81	572.21
37	993.55	155.52	87	967.53	364.84	137	928.93	576.48
38	993.19	159.70	88	966.87	369.04	138	928.05	580.76
39	992.81	163.88	89	966.21	373.25	139	927.16	585.04
40	992.44	168.06	90	965.54	377.45	140	926.26	589.32
41	992.05	172.24	91	964.86	381.65	141	925.37	593.60
42	991.65	176.41	92	964.18	385.86	142	924.46	597.88
43	991.25	180.59	93	963.50	390.07	143	923.56	602.17
44	990.85	184.77	94	962.81	394.27	144	922.64	606.46
45	990.43	188.95	95	962.12	398.48	145	921.73	610.76
46	990.01	193.13	96	961.42	402.69	146	920.81	615.05
47	989.58	197.31	97	960.72	406.90	147	919.88	619.35
48	989.14	201.49	98	960.01	411.11	148	918.95	623.65
49	988.70	205.67	99	959.30	415.33	149	918.02	627.95
50	988.25	209.85	100	958.58	419.54	150	917.08	632.26

A2. When pressure is higher than 1.0MPa but less than or equal to 2.5MPa:

Table 2 When $P = 1.6\text{MPa}$, temperature $1^\circ\text{C} \sim 150^\circ\text{C}$

Temp ($^\circ\text{C}$)	Density (kg/m^3)	Enthalpy (kJ/kg)	Temp ($^\circ\text{C}$)	Density (kg/m^3)	Enthalpy (kJ/kg)	Temp ($^\circ\text{C}$)	Density (kg/m^3)	Enthalpy (kJ/kg)
1	1000.7	5.7964	51	988.23	214.89	101	958.33	424.51
2	1000.7	10.004	52	987.77	219.07	102	957.61	428.72
3	1000.7	14.209	53	987.30	223.25	103	956.88	432.93
4	1000.7	18.411	54	986.83	227.42	104	956.15	437.15
5	1000.7	22.611	55	986.35	231.60	105	955.41	441.37
6	1000.7	26.808	56	985.86	235.78	106	954.67	445.59
7	1000.6	31.004	57	985.37	239.96	107	953.92	449.81
8	1000.6	35.197	58	984.87	244.14	108	953.17	454.03
9	1000.5	39.389	59	984.36	248.33	109	952.41	458.25
10	1000.4	43.579	60	983.85	252.51	110	951.65	462.48
11	1000.3	47.768	61	983.33	256.69	111	950.89	466.70
12	1000.2	51.956	62	982.81	260.87	112	950.12	470.93
13	1000.1	56.142	63	982.28	265.05	113	949.34	475.16

tPrime™ 280T-S Ultrasonic Heat Meter

14	999.95	60.327	64	981.75	269.24	114	948.57	479.39
15	999.80	64.511	65	981.21	273.42	115	947.78	483.62
16	999.64	68.693	66	980.66	277.61	116	947.00	487.85
17	999.47	72.875	67	980.11	281.79	117	946.21	492.08
18	999.29	77.057	68	979.55	285.98	118	945.41	496.32
19	999.10	81.237	69	978.99	290.16	119	944.61	500.56
20	998.89	85.417	70	978.43	294.35	120	943.81	504.80
21	998.68	89.596	71	977.85	298.54	121	943.00	509.04
22	998.45	93.774	72	977.27	302.72	122	942.19	513.28
23	998.22	97.952	73	976.69	306.91	123	941.37	517.52
24	997.98	102.13	74	976.10	311.10	124	940.55	521.77
25	997.72	106.31	75	975.51	315.29	125	939.72	526.02
26	997.46	110.48	76	974.91	319.48	126	938.89	530.27
27	997.19	114.66	77	974.30	323.67	127	938.06	534.52
28	996.91	118.84	78	973.70	327.86	128	937.22	538.77
29	996.62	123.01	79	973.08	332.06	129	936.37	543.03
30	996.32	127.19	80	972.46	336.25	130	935.52	547.28
31	996.01	131.36	81	971.84	340.44	131	934.67	551.54
32	995.69	135.54	82	971.76	344.64	132	933.82	555.80
33	995.37	139.72	83	970.21	348.83	133	932.95	560.07
34	995.04	143.89	84	969.93	353.03	134	932.09	564.33
35	994.69	148.07	85	969.29	357.23	135	931.22	568.60
36	994.35	152.24	86	968.64	361.42	136	930.35	572.87

37	993.99	156.42	87	967.99	365.62	137	929.47	577.14
38	993.62	160.59	88	967.33	369.82	138	928.58	581.41
39	993.25	164.77	89	966.66	374.02	139	927.50	585.69
40	992.87	168.94	90	965.99	378.22	140	926.81	589.96
41	992.49	173.12	91	965.32	382.43	141	925.91	594.24
42	992.09	177.30	92	964.64	386.63	142	925.01	598.53
43	991.69	181.47	93	963.96	390.83	143	924.10	602.81
44	991.28	185.65	94	963.27	395.04	144	923.19	607.10
45	990.87	189.82	95	962.58	399.24	145	922.28	611.39
46	990.44	194.00	96	961.88	403.45	146	921.36	615.68
47	990.02	198.18	97	961.18	407.66	147	920.44	619.97
48	989.58	202.36	98	960.48	411.87	148	919.51	624.27
49	989.14	206.53	99	959.77	416.08	149	918.58	628.57
50	988.69	210.71	100	959.05	420.29	150	917.65	632.87

§8.5 Heat Meter Mounting Location

The first step in the installation process is to select an optimal location for installing the device in order to make the measurement reliable and accurate. A basic knowledge about the piping and its plumbing system would be advisable.

An optimal location would be defined as a long straight pipe line full of liquid that is to be measured; it can be in a vertical or horizontal position. Principles to select an optimal location:

- (1) The straight pipe should be long enough to eliminate irregular flow induced error. Typically, UM280T-S170315V2

the length of the straight pipe should be 5 times of the pipe diameter (5D) straight pipe run upstream and 2D straight pipe run downstream, the longer the better.

- (2) Make sure that the temperature of the mounting location does not exceed the range for the heat meter. When the meter is used as cold meter, remove the meter's main box and its mounting base and install the main box on a wall or other objects where the temperature is within 0~55°C. In addition, the meter box needs to be higher than the cold pipe, so that the condensed water on the cold pipe will not flow into the meter box along the wires. If the heating system is not running in winter, always empty the pipe. Otherwise, the pipe may burst when water freezes.
- (3) Select a relatively new straight pipe line if possible. Old pipe tends to have corrossions and depositions, which could affect the results.
- (4) If the flow meter is installed on the common return of two heating circuits (e.g. heating water and hot water), the mounting location must be at a sufficient distance, at least 10D, from the Tee, to ensure that the different temperatures homogenize.
- (5) 7 main box on a wall or other objects where the temperature is within 0~55°C. In addition, the meter box needs to be higher than the cold pipe, so that the condensed water on the cold pipe will not flow into the meter box along the wires. If the heating system is not running in winter, always empty the pipe. Otherwise, the pipe may burst when water freezes.
- (6) Select a relatively new straight pipe line if possible. Old pipe tends to have corrossions and depositions, which could affect the results.
- (7) If the flow meter is installed on the common return of two heating circuits (e.g. heating water and hot water), the mounting location must be at a sufficient distance, at least 10D, from the Tee, to ensure that the different temperatures homogenize.